

RAIL PROFILE GRINDING MACHINE

MP12 200 (code ST473A01)

BOLT HORNET

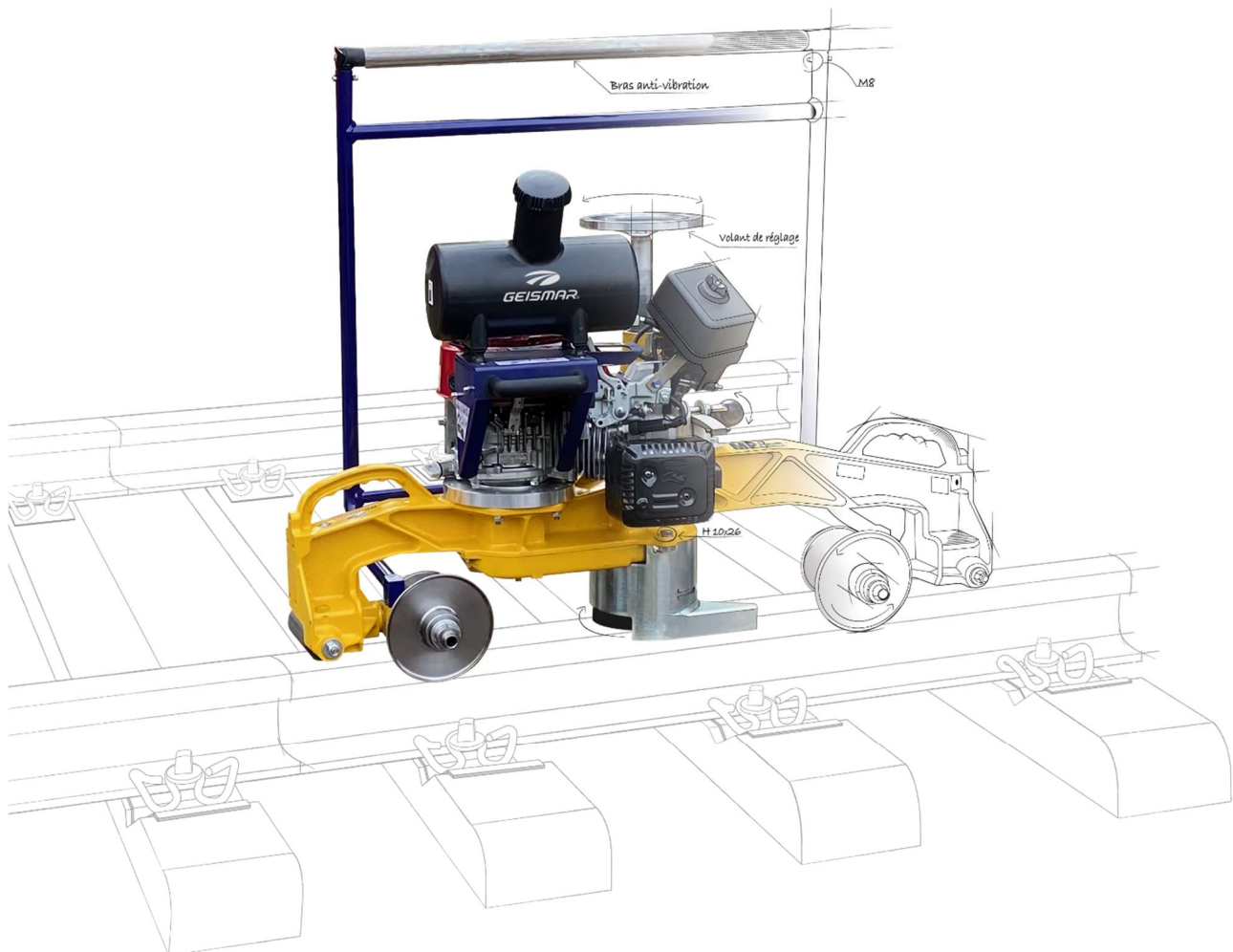

The rail profile grinding machine, model MP12 200 has been designed to grind **rail head and rail welds**, including the radius of curvature and the side of the rail head, **in one continuous operation and by a single operator**.

A powerful four-stroke petrol engine offers exceptional grinding performances. The MP12 200 is easily **inclined to 90° angle** to allow accurate grinding of the rail head to the correct profile.

The MP12 200 complies with EC standards.

1.	DESCRIPTION AND OPERATION	3
2.	TECHNICAL CHARACTERISTICS	4
3.	ACCESSORIES / OPTIONS / CONSUMABLES (with extra price)	5
3.1.	Holder end pieces, holder plates and corresponding grindstones	5
3.2.	Turn around kick stand	5
3.3.	Adaptation for grooved rails.....	5
3.4.	Adaptation for large rails.....	5
3.5.	Emergency stop	5
3.6.	Power take-off.....	6
3.6.1.	Flexible shaft.....	6
3.6.2.	Tool holder and corresponding grindstones	6

1. DESCRIPTION AND OPERATION

The MP12 200 has been designed with three main purposes:

- Excellent grinding accuracy;
- Engine power;
- Operator comfort and visibility



Inclinable operating arm with vibrations dampening system

Axle with locking knob to ease the grindstone removing



Reinforced V-belt transmission

Grindstone holder plate with 4 holes for Ø150mm grindstone

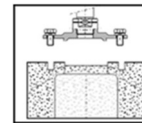

Grindstone cover with spark deflector for operator's safety

Engine from the professional range of Honda (GX range) suited for inclination to ensure proper lubrication

Air cooled, recoil starter and super silencer with protective grid

One hand wheel enabling continuous and accurate adjustment of grinding depth



The rail profile grinding machine, MP12 200 model, is composed of a grinding assembly mounted on a sturdy **mono-block frame made of high resistance light alloy**. It is fitted with **two support rollers** and **two guide rollers** enabling the machine to be inclined on the rail up to 90°. Grinding on either sides of the rail head is carried out by the operator turning around the machine. An optional turning around device by a kick stand is available to ease the turning operation by a single operator.

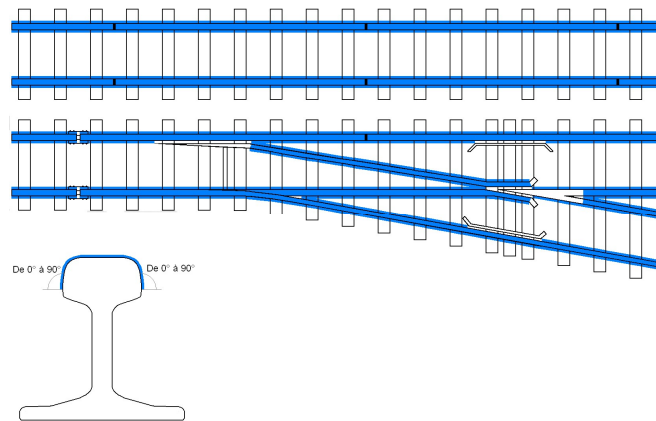

Grinding areas MP12 200

2. TECHNICAL CHARACTERISTICS

- 4-stroke petrol engine **Honda GX200** special: 5.3 HP (4.6 kW) net*
(with air cooling, recoil starter and exhaust guard) 6.7 HP (5 kW) gross **
at 4000 rpm
at 4000 rpm
- Rotation speed of the grindstone shaft: 3 600 rpm
- Total stroke of the grindstone: 62 mm
- Distance between supporting rollers: 1 050 mm
- Grindstone lowering per capstan turn: 5 mm
- Frame painting (powder coating paint quality): RAL1004
- Acoustic pressure at operator position level (L_{aeq}) ⁽¹⁾: 91 (±2) dB(A)
- Acoustic power level (L_{wa}) ⁽²⁾: 101 (±2) dB(A)
- Vibration level on main operating handle (A_{eq}) ⁽³⁾: 3,7 m.s⁻²
- Dimensions :
 - Length : 1 120 mm
 - Width : 720 mm
 - Height : 900 mm
- Masses :
 - When empty: 60 kg
 - In working order : 64,3 kg
- Normal service tools and user manual
- Machine supplied without grindstone and with a 4 holes holder plate for Ø150mm grindstone

* The engine power given in this document corresponds to the net power produced tested on a standard engine and measured to SAE J1349 standards at a given engine speed. This power value may vary on other standard engines.

** The engine power given in this document corresponds to the net power produced tested on a standard engine and measured to SAE J1995 standards at a given engine speed. This power value may vary on other standard engines.

The power produced by the engine mounted on the machine may vary for numerous reasons, such as the engine speed for a specific application, environmental conditions, etc.

The power indicated is for use of the machine between 0 and 1500 meters' altitude. Please consult for any applications at levels over 1500 m.

(1) Measurements taken during work as per NF EN ISO 11204.

(2) Measurements taken during work as per NF EN ISO 3746.

(3) Vibratory readings taken during work as per NF EN ISO 5349

3. ACCESSORIES / OPTIONS / CONSUMABLES (with extra price)

3.1. Holder end pieces, holder plates and corresponding grindstones

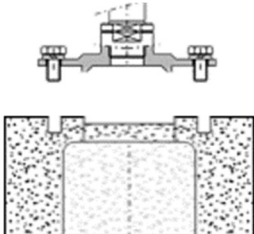
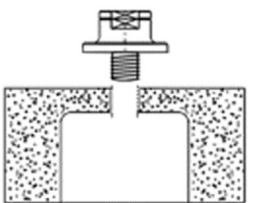
	Grindstone holder piece and plate	Grindstone	
		Dimensions	Reference
	4 holes stone holder ref. N07640 <i>(supplied with the machine)</i>	Ø150 x 72 mm	N00734
		Ø 125 x 60 mm	N00733
	6 holes M8 stone holder plate ref. N07238	Ø 150 x 65 mm	N00738
	stone holder plate Ø 125 - M20 ref. N07241	Ø 125 x 65 mm	N02780
Kit to convert from Ø 150 to Ø 125 M20 (guard+holder) ref. N07379			
	Holder end piece 5/8" ref. N07231	Ø 150 x 65 mm	N00737
		Ø 80 x 72 mm	N00731
		Ø 6" x 3"	N03243
	Holder end piece M20 ref. N07234	Ø 125 x 65 mm	N02780
		Ø 80 x 72 mm	N03313

3.2. Turn around kick stand

Ergonomic turn around system to facilitate the rotation of the machine by a single operator, without having to lift the machine

Ref. STE37000PQ

3.3. Adaptation for grooved rails

To use the MP12 200 on grooved rails

Ref. N07295

With this kit, the machine is then suited for Ø 80 x 72 mm grindstones to facilitate the grinding in the groove radius

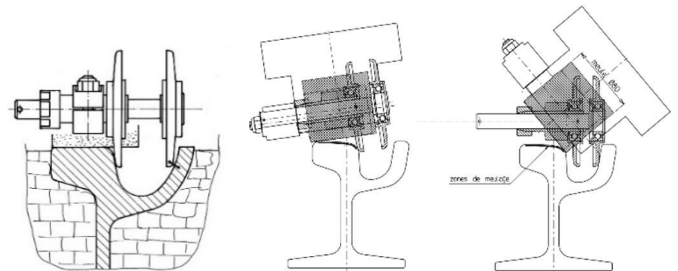

3.4. Adaptation for large rails

A standard MP12 200 is suited for rails up to 80mm head width. The kit for large rails enables to use the machine with rails up to 150mm head width.

Ref. STK37000-1

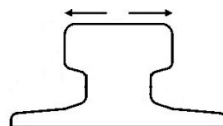

3.5. Emergency stop

The MP12 200 can be equipped with a mushroom type stop device.

Ref. STK12000EZ-1

3.6. Power take-off

To enable the mounting of a flexible shaft and tool holder

Réf. STK37000QS

3.6.1. Flexible shaft

Code	Flexible shaft type	Length
STA16300A	Without clutch	3 m
STA16300G	With clutch <i>Compulsory when using an EC compliant machine fitted with power take-off system STK37000QS</i>	4 m

3.6.2. Tool holder and corresponding grindstones

Tool holder		Grindstone	
Type	Reference	Dimensions	Reference
Straight tool holder suitable for grinding frog points and rail butt-end	STA600W	230 x 20 x 16 mm	N00742
Right angle tool holder suitable for grinding rail	STA600X	230 x 6,4x 22,2 mm	N00730
Right angle tool holder suitable for grinding rail	STA600Y	150 x 72 mm	N00734



In the interest of our customers and in anticipation of the constant improvements that we wish to bring to our equipment, we reserve the right to modify certain characteristics (without modifying its functions) during production. The track gauge and network type should be sent to us beforehand for verification, to ensure that the equipment offered is compatible.

Any modification and / or technical change arising after the date of the offer may result in a revision of the commercial offer.

Drawings and pictures may include some options and are not contractual.

Masses and dimensions may vary by ± 5%.